

Bid Document

Bid Details	
Bid End Date/Time	13-04-2022 19:00:00
Bid Opening Date/Time	13-04-2022 19:30:00
Bid Life Cycle (From Publish Date)	90 (Days)
Bid Offer Validity (From End Date)	60 (Days)
Ministry/State Name	Ministry Of Petroleum And Natural Gas
Department Name	Na
Organisation Name	N/a
Office Name	Visakhapatnam
Total Quantity	240
Item Category	DESK-CUM-BENCH FOR CLASS ROOM (Q3)
Minimum Average Annual Turnover of the Bidder	13 Lakh (s)
OEM Average Turnover (Last 3 Years)	100 Lakh (s)
Years of Past Experience required	3 Year (s)
MSE Exemption for Years Of Experience and Turnover	Yes
Startup Exemption for Years Of Experience and Turnover	Yes
Document required from seller	Experience Criteria,Past Performance,Bidder Turnover,OEM Authorization Certificate,OEM Annual Turnover *In case any bidder is seeking exemption from Experience / Turnover Criteria, the supporting documents to prove his eligibility for exemption must be uploaded for evaluation by the buyer
Past Performance	50 %
Bid to RA enabled	No
Time allowed for Technical Clarifications during technical evaluation	3 Days
Inspection Required (By Empanelled Inspection Authority / Agencies pre-registered with GeM)	No
Evaluation Method	Total value wise evaluation

EMD Detail

Required	No
----------	----

ePBG Detail

Advisory Bank	State Bank of India
ePBG Percentage(%)	3.00
Duration of ePBG required (Months).	14

(a). EMD & Performance security should be in favour of Beneficiary, wherever it is applicable.

Beneficiary:

Registrar (I/c)

Indian Institute of Petroleum and Energy, 2nd Floor, Main Building, AU College of Engineering, Visakhapatnam - 530003

(Dr. B Muralikrishna)

Splitting

Bid splitting not applied.

MII Purchase Preference

MII Purchase Preference	Yes
-------------------------	-----

MSE Purchase Preference

MSE Purchase Preference	Yes
-------------------------	-----

1. If the bidder is a Micro or Small Enterprise as per latest definitions under MSME rules, the bidder shall be exempted from the requirement of "Bidder Turnover" criteria and "Experience Criteria". If the bidder is OEM of the offered products, it would also be exempted from the "OEM Average Turnover" criteria. In case any bidder is seeking exemption from Turnover / Experience Criteria, the supporting documents to prove his eligibility for exemption must be uploaded for evaluation by the buyer.
2. If the bidder is a Startup, the bidder shall be exempted from the requirement of "Bidder Turnover" criteria and "Experience Criteria". If the bidder is OEM of the offered products, it would also be exempted from the "OEM Average Turnover" criteria. In case any bidder is seeking exemption from Turnover / Experience Criteria, the supporting documents to prove his eligibility for exemption must be uploaded for evaluation by the buyer.
3. The minimum average annual financial turnover of the bidder during the last three years, ending on 31st March of the previous financial year, should be as indicated above in the bid document. Documentary evidence in the form of certified Audited Balance Sheets of relevant periods or a certificate from the Chartered Accountant / Cost Accountant indicating the turnover details for the relevant period shall be uploaded with the bid. In case the date of constitution / incorporation of the bidder is less than 3-year-old, the average turnover in respect of the completed financial years after the date of constitution shall be taken into account for this criteria.
4. Experience Criteria: In respect of the filter applied for experience criteria, the Bidder or its OEM {themselves or through reseller(s)} should have regularly, manufactured and supplied same or similar Category Products to any Central / State Govt Organization / PSU / Public Listed Company for number of Financial years as indicated above in the bid document before the bid opening date. Copies of relevant contracts to be submitted along with bid in support of having supplied some quantity during each of the Financial year. In case of bunch bids, the category of primary product having highest value should meet this criterion.
5. OEM Turn Over Criteria: The minimum average annual financial turnover of the OEM of the offered product during the last three years, ending on 31st March of the previous financial year, should be as indicated in the bid document. Documentary evidence in the form of certified Audited Balance Sheets of relevant periods or a certificate from the Chartered Accountant / Cost Accountant indicating the turnover details for the relevant period shall be uploaded with the bid. In case the date of constitution / incorporation of the OEM is less than 3 year old, the average turnover in respect of the completed financial years after the date of constitution shall be taken into

account for this criteria.

6. Preference to Make In India products (For bids < 200 Crore):Preference shall be given to Class 1 local supplier as defined in public procurement (Preference to Make in India), Order 2017 as amended from time to time and its subsequent Orders/Notifications issued by concerned Nodal Ministry for specific Goods/Products. The minimum local content to qualify as a Class 1 local supplier is denoted in the bid document. If the bidder wants to avail the Purchase preference, the bidder must upload a certificate from the OEM regarding the percentage of the local content and the details of locations at which the local value addition is made along with their bid, failing which no purchase preference shall be granted. In case the bid value is more than Rs 10 Crore, the declaration relating to percentage of local content shall be certified by the statutory auditor or cost auditor, if the OEM is a company and by a practicing cost accountant or a chartered accountant for OEMs other than companies as per the Public Procurement (preference to Make-in -India) order 2017 dated 04.06.2020. Only Class-I and Class-II Local suppliers as per MII order dated 4.6.2020 will be eligible to bid. Non - Local suppliers as per MII order dated 04.06.2020 are not eligible to participate. However, eligible micro and small enterprises will be allowed to participate .In case Buyer has selected Purchase preference to Micro and Small Enterprises clause in the bid, the same will get precedence over this clause.

7. Purchase preference to Micro and Small Enterprises (MSEs): Purchase preference will be given to MSEs as defined in Public Procurement Policy for Micro and Small Enterprises (MSEs) Order, 2012 dated 23.03.2012 issued by Ministry of Micro, Small and Medium Enterprises and its subsequent Orders/Notifications issued by concerned Ministry. If the bidder wants to avail the Purchase preference, the bidder must be the manufacturer of the offered product in case of bid for supply of goods. Traders are excluded from the purview of Public Procurement Policy for Micro and Small Enterprises. In respect of bid for Services, the bidder must be the Service provider of the offered Service. Relevant documentary evidence in this regard shall be uploaded along with the bid in respect of the offered product or service. If L-1 is not an MSE and MSE Seller (s) has/have quoted price within L-1+ 15% (Selected by Buyer)of margin of purchase preference /price band defined in relevant policy, such Seller shall be given opportunity to match L-1 price and contract will be awarded for 25%(selected by Buyer) percentage of total QUANTITY.

8. Estimated Bid Value indicated above is being declared solely for the purpose of guidance on EMD amount and for determining the Eligibility Criteria related to Turn Over, Past Performance and Project / Past Experience etc. This has no relevance or bearing on the price to be quoted by the bidders and is also not going to have any impact on bid participation. Also this is not going to be used as a criteria in determining reasonableness of quoted prices which would be determined by the buyer based on its own assessment of reasonableness and based on competitive prices received in Bid / RA process.

9. Past Performance: The Bidder or its OEM {themselves or through re-seller(s)} should have supplied same or similar Category Products for 50% of bid quantity, in at least one of the last three Financial years before the bid opening date to any Central / State Govt Organization / PSU / Public Listed Company. Copies of relevant contracts (proving supply of cumulative order quantity in any one financial year) to be submitted along with bid in support of quantity supplied in the relevant Financial year. In case of bunch bids, the category related to primary product having highest bid value should meet this criterion.

DESK-CUM-BENCH FOR CLASS ROOM (240 pieces)

(Minimum 50% Local content required for qualifying as Class 1 Local Supplier)

Brand Type	Unbranded
------------	-----------

Technical Specifications

Buyer Specification Document	Download
------------------------------	--------------------------

Consignees/Reporting Officer and Quantity

S.No.	Consignee/Reporting Officer	Address	Quantity	Delivery Days
1	Koratana Ramakrishna	530003, Indian Institute of Petroleum & Energy, 2nd Floor, Main Building, Andhra University College of Engineering (A)	240	30

Buyer Added Bid Specific Terms and Conditions

1. Sample Clause

After award of contract - Successful Bidder shall have to get advance sample approved from buyer before bulk manufacturing / starting bulk supplies. Successful Bidder shall submit 1 samples for Buyer's approval, within 5 days of award of contract. Buyer shall, as per contract specifications framework, either approve the advance sample or will provide complete list of modification required in the sample within 5 days of receipt of advance sample. Seller shall be required to ensure supply as per approved sample with modifications as communicated by Buyer. If there is delay from buyer side in approval of advance sample - the delivery period shall be refixed without LD for the period of delay in sample approval. In case, the sample is found to have major deviations / not conforming to the Contract specifications, the buyer at its discretion may call for fresh samples for approval before allowing bulk supplies or may terminate the contract after notifying the deviations to the seller.

Unless otherwise provided in the contract, all samples required for test shall be supplied by the contractor free of cost. Where under the contract, the contractor is required to submit an advance sample, any expenses incurred by the contractor on or in connection with the production of stores in bulk, before the sample has been approved unconditionally shall be borne by the Seller and he shall not claim any compensation in the event of such sample being found unacceptable by the Buyer / Consignee.

2. Generic

After award of contract - Successful Bidder shall have to get Detailed Design Drawings approved from buyer before starting fabrication. Successful Bidder shall submit Detailed Design Drawings for Buyer's approval, within 5 days of award of contract. Buyer shall, either approve the drawings or will provide complete list of modification required in the drawings within 5 days. Seller shall be required to ensure supply as per approved Drawings with modifications as communicated by Buyer. If there is delay from buyer side in approval of drawing- the delivery period shall be refixed without LD for the period of delay in approval of Drawing.

3. Generic

Actual delivery (and Installation & Commissioning (if covered in scope of supply)) is to be done at following address Indian Institute of Petroleum and Energy, 2nd Floor, Main Building, AU College of Engineering, Visakhapatnam - 530003 2nd Floor Main Building AU College of Engineering Visakhapatnam, Andhra Pradesh - 530003.

4. Turnover

Bidder Turn Over Criteria: The minimum average annual financial turnover of the bidder during the last three years, ending on 31st March of the previous financial year, should be as indicated in the bid document. Documentary evidence in the form of certified Audited Balance Sheets of relevant periods or a certificate from the Chartered Accountant / Cost Accountant indicating the turnover details for the relevant period shall be uploaded with the bid. In case the date of constitution / incorporation of the bidder is less than 3 year old, the average turnover in respect of the completed financial years after the date of constitution shall be taken into account for this criteria.

5. Generic

Bidder financial standing: The bidder should not be under liquidation, court receivership or similar proceedings, should not be bankrupt. Bidder to upload undertaking to this effect with bid.

6. **Certificates**

Bidder's offer is liable to be rejected if they don't upload any of the certificates / documents sought in the Bid document, ATC and Corrigendum if any.

7. **Generic**

Bidders are advised to check applicable GST on their own before quoting. Buyer will not take any responsibility in this regards. GST reimbursement will be as per actuals or as per applicable rates (whichever is lower), subject to the maximum of quoted GST %.

8. **Generic**

Bidder shall submit the following documents along with their bid for Vendor Code Creation:

- a. Copy of PAN Card.
- b. Copy of GSTIN.
- c. Copy of Cancelled Cheque.
- d. Copy of EFT Mandate duly certified by Bank.

9. **Generic**

Consortium: In case of Contracts, wherein the seller alone does not have necessary expertise, the seller can form consortium with other sellers for submission of the bid, with one of the consortium company as leader. However, each and every member of the consortium shall be equally responsible for the complete execution of the project contract. An undertaking to this effect is to be uploaded with bid.

10. **Warranty**

Warranty period of the supplied products shall be 1 years from the date of final acceptance of goods or after completion of installation, commissioning & testing of goods (if included in the scope of supply), at consignee location. OEM Warranty certificates must be submitted by Successful Bidder at the time of delivery of Goods. The seller should guarantee the rectification of goods in case of any break down during the guarantee period. Seller should have well established Installation, Commissioning, Training, Troubleshooting and Maintenance Service group in INDIA for attending the after sales service. Details of Service Centres near consignee destinations are to be uploaded along with the bid.

11. **Generic**

Experience Criteria: The Bidder or its OEM {themselves or through reseller(s)} should have regularly, manufactured and supplied same or similar Category Products to any Central / State Govt Organization / PSU / Public Listed Company for 3 years before the bid opening date. Copies of relevant contracts to be submitted along with bid in support of having supplied some quantity during each of the year. In case of bunch bids, the primary product having highest value should meet this criterion.

12. **Past Project Experience**

For fulfilling the experience criteria any one of the following documents may be considered as valid proof for meeting the experience criteria:

- a. Purchase Order copy along with Invoice(s) with self-certification by the bidder that supplies against the invoices have been executed.
- b. Execution certificate by client with order value.
- c. Any other document in support of order execution like Third Party Inspection release note, etc.

13. **Generic**

OPTION CLAUSE: The Purchaser reserves the right to increase or decrease the quantity to be ordered up to 25 percent of bid quantity at the time of placement of contract. The purchaser also reserves the right to increase the ordered quantity by up to 25% of the contracted quantity during the currency of the contract at the contracted rates. Bidders are bound to accept the orders accordingly.

14. Financial Criteria

NET WORTH: Net Worth of the OEM should be positive as per the last audited financial statement.

15. Turnover

OEM Turn Over Criteria: The minimum average annual financial turnover of the OEM of the offered product during the last three years, ending on 31st March of the previous financial year, should be as indicated in the bid document. Documentary evidence in the form of certified Audited Balance Sheets of relevant periods or a certificate from the Chartered Accountant / Cost Accountant indicating the turnover details for the relevant period shall be uploaded with the bid. In case the date of constitution / incorporation of the OEM is less than 3 year old, the average turnover in respect of the completed financial years after the date of constitution shall be taken into account for this criteria. In case of bunch bids, the OEM of CATEGORY RELATED TO primary product having highest bid value should meet this criterion.

16. Scope of Supply

Scope of supply (Bid price to include all cost components) : Supply Installation Testing and Commissioning of Goods

17. Warranty

Timely Servicing / rectification of defects during warranty period: After having been notified of the defects / service requirement during warranty period, Seller has to complete the required Service / Rectification within 7 days time limit. If the Seller fails to complete service / rectification with defined time limit, a penalty of 0.5% of Unit Price of the product shall be charged as penalty for each week of delay from the seller. Seller can deposit the penalty with the Buyer directly else the Buyer shall have a right to recover all such penalty amount from the Performance Security (PBG). Cumulative Penalty cannot exceed more than 10% of the total contract value after which the Buyer shall have the right to get the service / rectification done from alternate sources at the risk and cost of the Seller besides forfeiture of PBG. Seller shall be liable to re-imburse the cost of such service / rectification to the Buyer.

18. Generic

1. The Seller shall not assign the Contract in whole or part without obtaining the prior written consent of buyer.
2. The Seller shall not sub-contract the Contract in whole or part to any entity without obtaining the prior written consent of buyer.
3. The Seller shall, notwithstanding the consent and assignment/sub-contract, remain jointly and severally liable and responsible to buyer together with the assignee/ sub-contractor, for and in respect of the due performance of the Contract and the Sellers obligations there under.

19. Generic

Without prejudice to Buyer's right to price adjustment by way of discount or any other right or remedy available to Buyer, Buyer may terminate the Contract or any part thereof by a written notice to the Seller, if:

- i) The Seller fails to comply with any material term of the Contract.
- ii) The Seller informs Buyer of its inability to deliver the Material(s) or any part thereof within the stipulated Delivery Period or such inability otherwise becomes apparent.
- iii) The Seller fails to deliver the Material(s) or any part thereof within the stipulated Delivery Period and/or to replace/rectify any rejected or defective Material(s) promptly.
- iv) The Seller becomes bankrupt or goes into liquidation.
- v) The Seller makes a general assignment for the benefit of creditors.
- vi) A receiver is appointed for any substantial property owned by the Seller.
- vii) The Seller has misrepresented to Buyer, acting on which misrepresentation Buyer has placed the Purchase Order on the Seller.

20. Generic

While generating invoice in GeM portal, the seller must upload scanned copy of GST invoice and the screenshot of GST portal confirming payment of GST.

Disclaimer

The additional terms and conditions have been incorporated by the Buyer after approval of the Competent Authority in Buyer Organization. Buyer organization is solely responsible for the impact of these clauses on the bidding process, its outcome and consequences thereof including any eccentricity / restriction arising in the bidding process due to these ATCs and due to modification of technical specification and / or terms and conditions governing the bid. Any clause incorporated by the Buyer such as demanding Tender Sample, incorporating any clause against the MSME policy and Preference to make in India Policy, mandating any Brand names or Foreign Certification, changing the default time period for Acceptance of material or payment timeline governed by OM of Department of Expenditure shall be null and void and would not be considered part of bid. Further any reference of conditions published on any external site or reference to external documents / clauses shall also be null and void. If any seller has any objection / grievance against these additional clauses or otherwise on any aspect of this bid, they can raise their representation against the same by using the Representation window provided in the bid details field in Seller dashboard after logging in as a seller within 4 days of bid publication on GeM. Buyer is duty bound to reply to all such representations and would not be allowed to open bids if he fails to reply to such representations.

[This Bid is also governed by the General Terms and Conditions](#)

In terms of GeM GTC clause 26 regarding Restrictions on procurement from a bidder of a country which shares a land border with India, any bidder from a country which shares a land border with India will be eligible to bid in this tender only if the bidder is registered with the Competent Authority. While participating in bid, Bidder has to undertake compliance of this and any false declaration and non-compliance of this would be a ground for immediate termination of the contract and further legal action in accordance with the laws.

---Thank You---



INDIAN INSTITUTE OF PETROLEUM AND ENERGY

TECHNICAL SPECIFICATIONS AND OTHER TERMS & CONDITIONS **FOR PROCUREMENT OF TWO SEATER DESK-CUM-BENCH** **FOR CLASS ROOMS**

Technical Specifications:

SI No.	Description of Items	Qty (in Nos.)
01	Supplying, Installation and commissioning of " Two-Seater Desk cum Bench " for Class Rooms with the following specifications Desk top: 31" H x 48" L x 15" W Seat top: 20" H x 48" L x 12" W Back Rest: 11" H x 48" L & all as per drawing including cost and taxes of all materials, labour, T&P, carriage, loading and unloading, delivery and installation at site etc., are included.	240
02	The Desk Panels are to be made from 18mm thick pre-laminated boards with PVC edge banding on all sides.	
03	Understructure should be made of 25.4mm x 25.4mm x 1.2mm thick powder coated (black) ERW rectangular tubes at base which are to be welded to the desk and seat supports that are made of 1.0mm thick powder coated MS'C' sections.	
04	Stiffeners are to be provided between 2 vertical frames at base and back of seat are made from 25.4mm x 25.4mm x 1.2mm thick powder coated (black) ERW rectangular tubes. The Tubes are closed with plastic caps.	
05	Additional horizontal supports of 1.5mm thick powder coated MS'C' section are to be placed below the desk and seat to add the rigidity of the structure.	
06	The Storage shelved are to be made from 0.6mm thick powder coated MS Sheet which should be affixed below desk top with folded edge on the open side, full covered other three sides (left, right and Front).	

For any queries, please contact:

- procurement section, IIPE, email id : procurement@iipe.ac.in (Tele : 0891-2856015)

DRAWING OF THE DESK-CUM-BENCH:

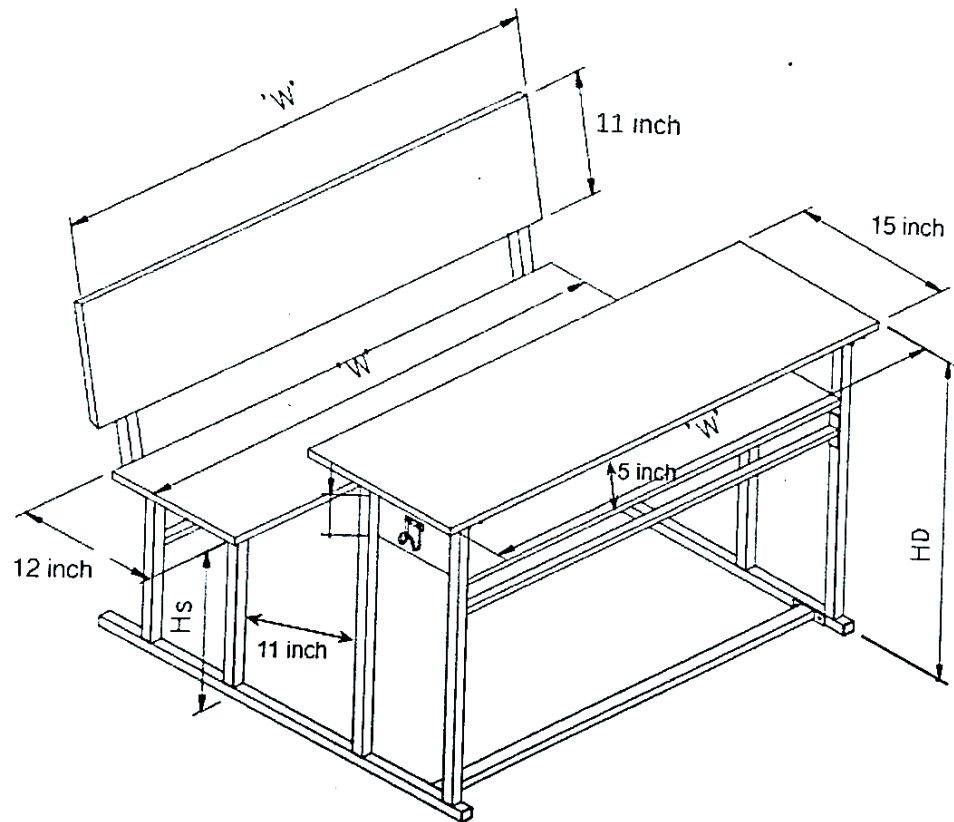

Dimensions

W	Hd	Hs
48 inch	31 inc	20 inc

*Hd – Desk Height

W – Width

*Hs – Seat Height

TERMS & CONDIDITIONS

1. The Vender should be exclusively a manufacturer/dealer/agent/authorized distributor of furniture and should have registered office anywhere in India, with a branch office/ authorized dealer in **VISAKHAPATNAM**.
2. The bidder has to provide one model of sample of required furniture for Technical evaluation. Prototype model is also acceptable for the purpose. The vendors selected after technical evaluation will be called for price bid opening. Bids submitted without sample will not be considered for technical evaluation.
3. Dealership certificate on the offered products in case the vendor is a dealer.
4. List of reputed organizations/Institutions, where similar orders have been executed.
5. Validity: Quoted rates must be valid for 120 days.
6. Warranty/Guarantee: The supplier shall warranty equipment/ material for a minimum period of One (01) year and support for repair till 05 years after warranty period, following satisfactory acceptance of the material. The defects, if any during the guarantee/warrantee period are to be rectified free of charge by arranging free replacement wherever necessary. All expenditure including government levies on account of the replacement are to be borne by the supplier /agent.
7. Delivery: Unless otherwise stated door delivery of goods at IIFE Visakhapatnam, will have to be maximum within 30 days from the date of issue of the Purchase Order or as given in the purchase order.
8. Dealership Certificate: Dealership certificate (in case of dealers) and standard Technical literature on the offered products must be enclosed.
9. Ground for Rejection of Quotation: The quotations are liable to be rejected if the fore going conditions are not complied with. The quotation should be complete in all respects and duly signed wherever required. Incomplete and unsigned offer will not be accepted.
10. Terms of Payment: Payment will be made maximum within 30 days from the date of successful delivery and installation and submission of PBG where required, generally through RTGS. In case of payment is to be made by DD, the draft commission will be deducted from the bill amount. Part payment for part delivery will not be allowed.
11. Performance Security: Payment will be made 100% against submission of 3% performance security (BG). In the absence of submission of BG, payment will be made 90% and balance 10% after submission of BG. The performance security should remain valid for a period of sixty days beyond the date of completion of all contractual obligation of the supplier including warranty obligations. Performance Security may be furnished in the form of account payee demand draft, fixed deposit receipt from a nationalized bank in favour of Registrar, IIFE Visakhapatnam. The BG is to be submitted direct through the bank to avoid delay in obtaining confirmation.

12. **Liquidity Damages:** If a firm accepts an order and fails to execute the order in full or part as per the terms and conditions stipulated therein, it will be open to this institute to recover liquidated damages from the firm at the rate **0.5%** of the value of the undelivered stores per Week or part thereof, subject to a maximum of **10%** of the value of undelivered stores. It will also be open to this institute alternatively, to arrange procurement of the required stores from any other source at the risk and expense of the firm, which accepted the order but failed to execute the order according to stipulated agreed upon.

13. All the documents as per the tender document are to be submitted after duly certified by the authorized signatories.

14. Furnish the copy of PAN & GST number etc., in quotation for record purpose.

15. This bid is also governed by General Terms and conditions on GeM.

16. **Public Procurement (Preference to Make in India), Order 2017:**

(a) IIFE Visakhapatnam shall compare all substantially responsive bids to determine the lowest valued bid. This Institute is following and abide with the Public Procurement (Preference to Make in India), Order 2017, DIPP, MoCI Order No. P-45021/2/2017B.E.II dated 15th June 2017 and its subsequent amendments. Accordingly, preference will be given to the Make in India products while evaluating the bids, however, it is the sole responsibility of the bidder(s) to specify the product quoted by them is of Make in India product along with respective documentary evidence as stipulated in the aforesaid order in the technical bid itself.

(b) As per the above order and its subsequent amendments "Local Content" means the amount of value added in India which shall be value of the item procured (excluding net domestic indirect taxes) minus the value of the imported content in the item (including all the custom duties) as a proportion of the total value, in percent. Accordingly, the suppliers will be classified in following categories.

(i) Class I local Supplier – has local content equal to more than 50%;

(ii) Class II local Supplier – has local content more than 20% but less than 50%.

(c) **Verification of Local Content:** The Class I Local Supplier/ Class II Local Supplier/ Non-Local Supplier at the time of bidding shall be required to indicate the percentage of local content and provide self-certification that the items offered meet the local content requirement. The details of the location(s) at which the local value addition is made also needs to be specified. In case of procurement in excess of Rs.10 Crores, the suppliers shall be required to provide the certificate from the statutory auditor or cost auditor of the company giving the percentage of local content.

The bidders can be debarred for a period up to two years as per Rule 151(iii) of GFR 2017, in case of false declaration.

17. **Requirement of registration:** With reference to Ministry of Finance (MoF) OM No. 6/18/2019-PPD dated 23rd July 2020:-

(a) Any bidder from a country sharing a land border with India will be eligible to bid in this tender only if the bidder is registered with the Department for Promotion of Industry and Internal Trade (DPIIT).

(b) "Bidder" (including the term 'tenderer', 'consultant' or 'service provider' in certain contexts) means any person or firm or company, including any member of a consortium or joint venture (that is an association of several persons, or firms or companies), every artificial juridical person not falling in any of the descriptions of bidders stated hereinbefore, including any agency branch or office controlled by such person, participating in a procurement process.

(c) "Bidder" from a country which shares a land border with India" for the purpose of this Order means:

- (i) An entity incorporated, established or registered in such a country; or
- (ii) A subsidiary of an entity incorporated, established or registered in such a country; or
- (iii) An entity substantially controlled through entities incorporated, established or registered in such a country; or
- (iv) An entity whose beneficial owner is situated in such a country; or
- (v) An Indian (or other) agent of such an entity; or
- (vi) A natural person who is a citizen of such a country; or
- (vii) A consortium or joint venture where any member of the consortium or joint venture falls under any of the above

For details about registration procedures please visit the above-mentioned OM. Mandatory documentary evidence regarding the bidder's registration with DPIIT is to be submitted along with the tender, failing which the tender shall be liable for rejection. Bidders are also requested to submit the Model Certificates **as per Annexure** for this tender as mentioned in the Ministry of Finance OM No. 6/18/2019-PPD dated 23rd July 2020.

18. **Note for MSME/ MSIC/ Start up Bidder:** In the view of the bidder, any exemption/ relaxation is applicable to them from any of the eligibility requirements, under any Rules/ guidelines/ directives of the GoI, bidder may submit their claim for the applicable exemption/ relaxation, quoting the valid Rule/ guidelines/ directives with a copy of such notification. In this case the bidder must submit necessary and sufficient documents along with the technical bid, in support of their claim. The relevant and valid certificates in support of claim of exemption must be submitted along with the Technical Bid.

19. Director of IPE Visakhapatnam may accept or reject any quotation in part or full without assigning any reason and does not bind himself to accept the lowest bid. The Institute at its discretion may change the quantity/ upgrade the criteria/ drop any item or part thereof at any time before placing the Purchase Order:

20. In case of any disputes, the decision of the Director of this Institute shall be final and binding on the Bidders.

21. Jurisdiction: The disputes, legal matters, court matters, if any, shall be subject to Visakhapatnam, Andhra Pradesh Jurisdiction only.

FORMAT OF COMPLIANCE STATEMENT OF SPECIFICATIONS

1	2	3	4	5	6
Sl.	Name of specifications/part / Accessories of tender enquiry As per technical specifications of the Tender Document.	Specifications of quoted Model/ Item	Compliance Whether "YES" or "NO"	Deviation, if any, to be indicated in unambiguous terms	Whether the compliance / deviation is clearly mentioned in technical leaflet/ literature
1					
2					
3					

Note : Bidders are required to fill this table as per the specifications given in the this Tender Document.

The bidder should also submit the Boucher with technical details of the product supporting the compliance statement

Signature of the Bidder: _____

Name :

Stamp

MANUFACTURER'S AUTHORIZATION FORM

[The Bidder shall require the Manufacturer to fill in this Form in accordance with the instructions indicated. This letter of authorization should be on the letterhead of the Manufacturer and should be signed by a person with the proper authority to sign documents that Are binding on the Manufacturer]

Date: [Insert date (as Day, month and year) of Bid submission]

Tender No.: [Insert number from Invitation for Bids]

To: [Insert complete name and address of Purchaser]

WHEREAS

We [insert complete name of Manufacturer], who are official manufacturers of [Insert type of goods manufactured] having factories at [insert full address of Manufacturer's factories], do hereby authorize [insert complete name of Bidder] to submit a bid the purpose of which is to provide the following goods, manufactured by us [insert name and or brief description of the goods], and to subsequently negotiate and sign the contract.

We hereby extend our full guarantee and complete comprehensive warranty in accordance with the Terms and Conditions of Contract with respect to the Goods offered by the above firm for the complete warranty period.

Signed: [insert signature(s) of authorized representative(s) of the Manufacturer]

Name: [insert complete name(s) of authorized representative(s) of the Manufacturer]

Title: [insert title]

Duly authorized to sign this Authorization on behalf of: [insert complete name of Bidder]

Dated on _____ day of _____ [insert date of sign in]

BID SECURING DECLARATION FORM

Date: _____

Tender No. _____

To (insert complete name and address of the purchaser)

I/We. The undersigned, declare that:

I/We understand that, according to your conditions, bids must be supported by a Bid Securing Declaration.

I/We accept that I/We may be disqualified from bidding for any contract with you for a period of two year from the date of notification if I am /We are in a breach of any obligation under the bid conditions, because I/We

- a) have withdrawn/ modified/ amended, impairs or derogates from the tender, my/ our Bid during the period of bid validity specified in the form of Bid; or
- b) having been notified of the acceptance of our Bid by the purchaser during the period of bid validity (i) fail or reuse to execute the contract, if required, or (ii) fail or refuse to furnish the Performance Security, in accordance with the Instructions to Bidders.

I/We understand this Bid Securing Declaration shall cease to be valid if I am/we are not the successful Bidder, upon the earlier of (i) the receipt of your notification of the name of the successful Bidder; or (ii) thirty days after the expiration of the validity of my/our Bid.

Signed: (insert signature of person whose name and capacity are shown)

in the capacity of (insert legal capacity of person signing the Bid Securing Declaration)

Name: (insert complete name of person signing he Bid Securing Declaration)

Duly authorized to sign the bid for an on behalf of (insert complete name of Bidder)

Dated on _____ day of _____ (insert date of signing)

Corporate Seal (where appropriate)

(Note: In case of a Joint Venture, the Bid Securing Declaration must be in the name of all partners to the Joint Venture that submits the bid)

PREVIOUS SUPPLY ORDERS FORMAT

Name of the Firm _____

Order placed by <i>{Full address of Purchaser}</i>	Order No. and Date	Description and quantity of ordered equipment	Value of order	Date of completion of delivery as per contract	Date of actual completion of delivery	Remarks indicating reasons for late delivery, if any and justification for price difference of their supply order & those quoted to us.	Has the equipment been installed satisfactorily?	Contact Person along with Telephone no., Fax no. and e-mail address.

Signature and Seal of the Manufacturer/ bidder

Place:

Date:

BIDDER INFORMATION FORM

Company Name: _____

Registration Number : _____

Registration Address : _____

Name of Partners /Director : _____

City : _____ Postal Code : _____

Company's Establishment Year : _____

Company's Nature of Business : _____

Contact Details:

Contact Name : _____ Designation : _____

Email Id : _____ Mobile No : _____

Company's Legal Status (<i>tick on appropriate option</i>)	1) Limited Company	
	2) Undertaking	
	3) Joint Venture	
	4) Partnership	
	5) Others	
Company Category	1) Micro Unit as per MSME	
	2) Small Unit as per MSME	
	3) Medium Unit as per MSME	
	4) Ancillary Unit	
	5) SSI	6) Others

Details of Branch office/ Authorised dealer in Visakhapatnam:

Contact Person Name & designation: _____

Address: _____

Email id: _____ Mobile/ Telephone No. _____

Other Details

Vendor's PAN No. _____

Vendor's CST No/LST No/WCT No/TIN No: _____

CERTIFICATE BY BIDDER- DPIIT REGISTRATION

(Certificate on Company Letterhead)

I have read the clause regarding restrictions on procurement from a bidder of a country which shares a land border with India; I certify that this bidder is not from such a country or, / if from such a county, has been registered with the Competent Authority (copy of the Registration Certificate enclosed) .

I hereby certify that this bidder fulfils all requirements in this regard and is eligible to be considered for this tender no. _____ dated _____ listed by IIFE
Visakhapatnam.

Signature with Date
and Stamp of the Bidder

DECLARATION FOR LOCAL CONTENT

(to be given on Company Letter Head – for tender value below Rs. 10 crores)

Date:

To

The Director
Indian Institute of Petroleum and Energy
Visakhapatnam – 530003

Sub: Declaration of Local Content

Tender Reference No. _____

Name of Tender/ Work : _____

1. Country of Origin of Goods being offered : _____
2. We hereby declare that items offered has _____ % local content (Please provide exact %).
3. Details of location at which local value addition will be made/ made : (Complete address to be mentioned) _____

“ Local Content” means the amount of value added in India which shall, be the total value of the item being offered minus the value of the imported content in the item (including all customs duties) as a proportion of the total value, in percent.

“False declaration will be in breach of Code of Integrity under Rule 175 ((1)(i)(h) of the General Financial Rules for which a bidder or its successors can be debarred for up to two years as per Rule 151 (iii) of the General Financial Rules along with such other actions as may be permissible under law.”

Yours Faithfully,

(Signature of the Bidder, with official seal)

ACCEPTANCE OF TENDER TERMS
(To be given on Company Letter Head)

Date: DD/MM/YYYY

To,

The Director
Indian Institute of Petroleum and Energy
Visakhapatnam - 530003

Sub: Acceptance of Terms & Conditions of Tender.

Tender Reference No: _____

Name of Tender / Work: _____

Dear Sir,

1. I/ We have downloaded / obtained the tender document(s) for the above mentioned 'Tender' from the web site(s) namely _____ as per your advertisement, given in the above mentioned website(s).
2. I/ We hereby certify that I/ we have read the entire terms and conditions of the tender documents (including all documents like annexure(s), schedule(s), etc.), which form part of the contract agreement and I/ we shall abide hereby by the terms/ conditions/ clauses contained therein.
3. The corrigendum(s) issued from time to time by your department/ Organisation too have also been taken into consideration, while submitting this acceptance letter.
4. I/ We hereby unconditionally accept the tender conditions of above mentioned tender document(s)/ corrigendum(s) in its totality/ entirety.
5. I/ We certify that all information furnished by our Firm is true & correct and in the event that the information is found to be incorrect/ untrue or found violated, then your department/ Organization shall without giving any notice or reason therefore or summarily reject the bid or terminate the contract, without prejudice to any other rights or remedy including that we can be debarred for a period up to two years as, per Rule 151(iii) of GFR 2017, in case of false declaration.

Yours Faithfully,

(Signature of the Bidder, with Official Seal)